

T SERIES

Sensor Housed in Probe, Protects Against Corrosion



Duct mount temperature sensors from Veris are pre-calibrated and housed in sturdy stainless steel probes. The devices are easy to install, durable, and highly accurate.

SPECIFICATIONS

Wiring	22 AWG; 2-wire: RTD/Thermistor, 4 to 20 mA; 3-wire: Linitemp
--------	---

TEMPERATURE TRANSMITTER OPTION

Input Power	4 to 20 mA models: Loop powered Class 2, 12 to 30 Vdc only, 30 mA max; 0-5/0-10 V models: Class 2, 12 to 30 Vdc/24 Vac, 50/60 Hz, 15 mA max
Temp. Output	2-wire, loop powered 4 to 20 mA 3-wire, 0-5V/0-10Vdc
Sensor Type	Solid-state, integrated circuit
Transmitter Accuracy	±0.5 °C (±.9 °F) typical*
Ranges	Selectable 0 to 50 °C (32 to 122 °F) or -40 to 50 °C (-40 to 122 °F)

LINITEMP OPTION

Input Power	5 to 30 Vdc
Output	10 mV/°C
Operating Temp	-25 to 105 °C (-13 to 221 °F)
Calibration Offset	1.5 °C (2.7 °F) typical; 2.5 °C (4.5 °F) max. at 25 °C (77 °F)**

Cost effective

Cost-effective, high accuracy thermistors or RTDs available with or without a junction box

Durable

Corrosion resistant stainless steel probe design

No calibration

No calibration required

APPLICATIONS

- Duct systems
- Industrial

Offset over Temp	1.8 °C (3.24 °F) typical; 3.0 °C (5.4 °F) max. over 0 to 70 °C (32 to 158 °F) range 2.0 °C (3.6 °F) typical, 3.5 °C (6.3 °F) max. over -25 to 105 °C (-13 to 221 °F) range
------------------	---

RESISTIVE OPTION

Operating Temp	-25 to 105 °C (-13 to 221 °F)
----------------	-------------------------------

WARRANTY

Limited Warranty	5 years
------------------	---------

AGENCY APPROVALS



*Room temperature offset documented on each unit.

**The CE mark indicates RoHS2 compliance. Please refer to the CE Declaration of Conformity for additional details.



TD

Dimensional Drawing

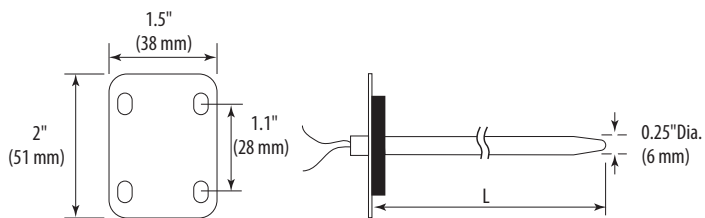

TF

Dimensional Drawing

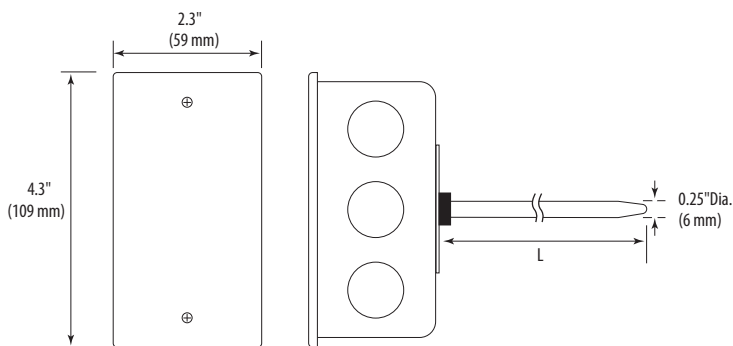

TK

Dimensional Drawing

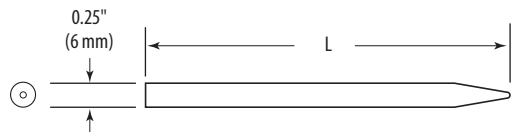

TDDA

Dimensional Drawing

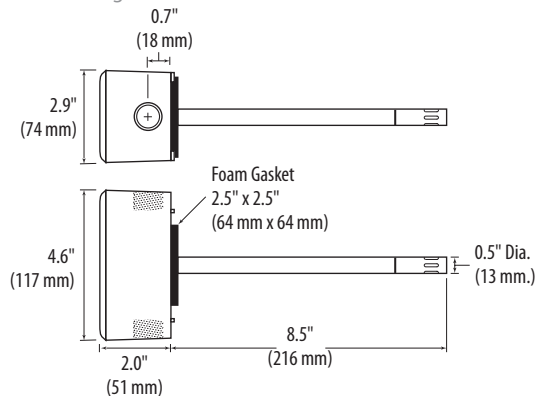

TG

Dimensional Drawing

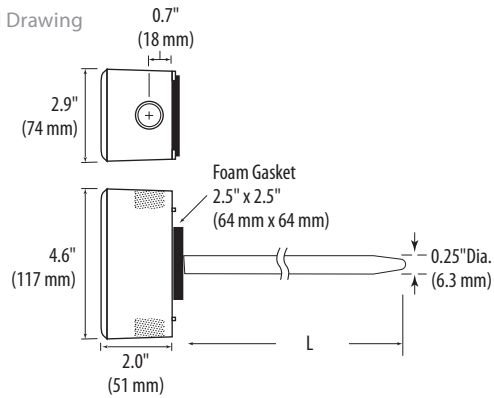

ORDERING INFORMATION

RTD/Thermistor Models

Enclosure	Immersion Probe Length "L"	Sensor Type	Output	Calibration Certificate
T			RØ	
D = Duct	B = 4" (102mm)*	B = 100R platinum, RTD	= Resistive Output	0 = None
K = Probe only (no mounting hardware)	C = 6" (152mm)	C = 1k platinum, RTD		1 = 1-point cal validation***
F = Duct with mounting box	D = 8" (203mm)	D = 10k T2, Thermistor		2 = 2-point cal validation***
G = Duct with water resistant housing	E = 12" (305mm)**	E = 2.2k, Thermistor		
	F = 18" (457mm)**	F = 3k, Thermistor		
	G = 24" (610mm)**	G = 10k CPC, Thermistor		
	K = 36" (914mm)**	H = 10k T3, Thermistor		
		I = 1k Balco (Nickel-iron) RTD		
		J = 10k Dale, Thermistor		
		K = 10k w/11k shunt, Thermistor		
		M = 20k NTC, Thermistor		
		N = 1800 ohm, Thermistor		
		P = 10mV/°C, Linitemp		
		R = 10k US, Thermistor		
		S = 10k 3A221, Thermistor		
		T = 100k, Thermistor		
		U = 20k "D", Thermistor		
		W = 10k T2 high accuracy, Thermistor		
		Y = 10k T3 high accuracy, Thermistor		

* TK model is 4 1/2" (115 mm)
 ** Not available with TK model
 *** Not available with W and Y high-accuracy thermistors

Examples:
 T D B D RØ 2

Transmitter Models

Output	Range	Cal Certificate
TDDA		
M = 4 to 20mA V = 5/10V	1 = -40 to 50 °C (-40 to 122 °F) 2 = 0 to 50 °C (32 to 122 °F)	0 = None 1 = 1 point Cal validation 2 = 2 point Cal validation

Example:
 TDDA V 2 0



THERMISTOR TABLE

Class	Pt RTD		Balco RTD	THERMISTOR				
	100 Ohm	1000 Ohm	1000 Ohm	10k Type 2	10k Type 3	10k Dale	10k "G" US	20k
Accuracy	±0.3°C	±0.3°C	±1% @70°C	±1.0°C	±0.2°C	±0.2°C	±0.2°C	Consult
	0.00385 curve	0.00385 curve		-50/150°C	0/70°C	-20/70°C	0/70°C	Factory
Temp. Response*	PTC	PTC	PTC	NTC	NTC	NTC	NTC	NTC

*PTC: Positive Temperature Coefficient *NTC: Negative Temperature Coefficient

STANDARD RTD AND THERMISTOR VALUES (Ohms Ω)

°C	°F	100 Ohm	1000 Ohm	1000 Ohm	10k Type 2	10k Type 3	10k Dale	10k "G" US	20k NTC
-50	-58	80.306	803.06	740.46	692,700	454,910	672,300	441,200	1,267,600
-40	-40	84.271	842.71	773.99	344,700	245,089	337,200	239,700	643,800
-30	-22	88.222	882.22	806.02	180,100	137,307	177,200	135,300	342,000
-20	-4	92.160	921.60	841.00	98,320	79,729	97,130	78,910	189,080
-10	14	96.086	960.86	877.46	55,790	47,843	55,340	47,540	108,380
0	32	100.000	1,000.00	913.66	32,770	29,588	32,660	29,490	64,160
10	50	103.903	1,039.03	952.25	19,930	18,813	19,900	18,780	39,440
20	68	107.794	1,077.94	991.82	12,500	12,272	12,490	12,260	24,920
25	77	109.735	1,097.35	1,013.50	10,000	10,000	10,000	10,000	20,000
30	86	111.673	1,116.73	1,035.18	8,055	8,195	8,056	8,194	16,144
40	104	115.541	1,155.41	1,077.68	5,323	5,593	5,326	5,592	10,696
50	122	119.397	1,193.97	1,120.52	3,599	3,894	3,602	3,893	7,234
60	140	123.242	1,232.42	1,166.13	2,486	2,763	2,489	2,760	4,992
70	158	127.075	1,270.75	1,210.75	1,753	1,994	1,753	1,990	3,512
80	176	130.897	1,308.97	1,254.55	1,258	1,462	1,258	1,458	2,516
90	194	134.707	1,347.07	1,301.17	919	1,088	917	1,084	1,833
100	212	138.506	1,385.06	1,348.38	682	821	679	816.8	1,356
110	230	142.293	1,422.93	1,397.13	513	628	511	623.6	1,016
120	248	146.068	1,460.68	1,447.44	392	486	389	481.8	770
130	266	149.832	1,498.32	1,496.28	303	380	301	376.4	591
Sensor Codes		B	C	I	D	H	J	R	M

To compute Linitemp Temperature
 mV reading/10 - 273.15 = Temperature in °C

