



SERIES ADPS/EDPS/BDPA/BYDS



# HVAC DIFFERENTIAL PRESSURE SWITCH

With Dual Scale Field Adjustable Set Point Knob



ADPS



EDPS

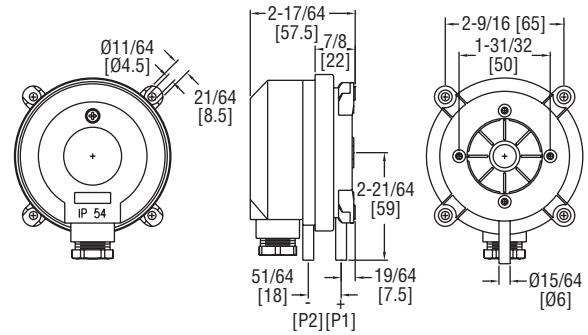

ADPS/EDPS/BYDS

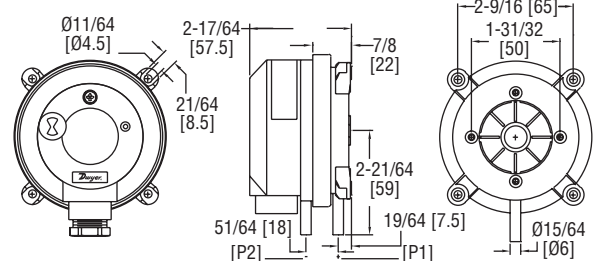

BDPA

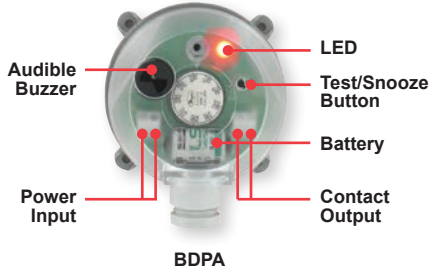

BDPA

The **SERIES ADPS/EDPS/BDPA/BYDS** Adjustable Differential Pressure Switch is designed for pressure, vacuum, and differential pressures. The dual scaled adjustment knob in inches water column and pascals allows changes to the switching pressure to be made without a pressure gage. The ADPS/EDPS/BDPA is available with settings from 0.08 in w.c. (20 Pa) up to 20 in w.c. (5000 Pa). The silicone diaphragm and PA 6.6 body make the series ADPS ideal for use with air and other noncombustible gases. Series EDPS models meet UL508 and are constructed of plenum rated plastics. The series BDPA Adjustable Differential Pressure Alarms offer a versatile range of configurations allowing utilization of their many features including buzzer and LED notification, and battery or line powered. The compact size, adjustment knob and low cost make the ADPS/EDPS/BDPA the perfect choice for HVAC applications.

**FEATURES/BENEFITS**

- Adjustment knob changes switching pressure easily with a pressure gage reducing components for application
- Low cost device makes it an excellent solution in BAS and HVAC applications requiring duct control and monitoring
- Relay contact allows simple integration with DDC or building systems

**APPLICATIONS**

- Air filter and ventilator monitoring
- Industrial cooling circuits
- Fire-protection damper control
- Ventilation duct monitoring
- Fan heater overheating protection
- Heat exchanger frost protection

**SPECIFICATIONS**

**Service:** Air and non-combustible, compatible gases.  
**Wetted Materials:** ADPS/BYDS: Diaphragm material: Silicone; Housing material: POM; Switch body: PA 6.6; Cover: Polystyrene; EDPS: Diaphragm material: Silicone; Housing material: Switch body: PA 6.6; Cover: Polystyrene; Materials UL 94 V-0 rated.  
**Temperature Limits:** Process and ambient temperature from -4 to 185°F (-20 to 85°C).  
**Pressure Limits:** Max. operating pressure: 40 in w.c. (10 kPa) for all pressure ranges.  
**Switch Type:** Single-pole double-throw (SPDT).  
**Electrical Rating:** Max. 1.5 A res./0.4 A ind./250 VAC, 50/60 Hz; Max. switching rate: 6 cycles/min.  
**Electrical Connections:** Push-on screw terminals. M20x1.5 with cable strain relief or optional 1/2" NPT.  
**Process Connections:** 5/16" (7.94 mm) outside diameter tubing, 1/4" (6.0 mm) inside diameter tubing.  
**Enclosure Rating:** NEMA 13 (IP54).  
**Mounting Orientation:** Vertically, with pressure connections pointing downwards.  
**Mechanical Working Life:** Over 106 switching operations.  
**Weight:** 5.6 oz (160 g).  
**Agency Approvals:** CE, ETL approved to UL508 and CSA C22.2#14 (EDPS only).

MODEL CHART - ADPS			
Model	Set Point Range in w.c. (Pa)	Approx. Dead Band @ Min Set Point in w.c. (Pa)	Approx. Deadband @ Max Set Point in w.c. (Pa)
ADPS-08-2-N	0.08 to 1.20 (20-300)	0.04 (10)	0.05 (12)
ADPS-04-2-N	0.12 to 1.60 (30-400)	0.06 (15)	0.09 (22)
ADPS-03-2-N	0.20 to 2.00 (50-500)	0.08 (20)	0.09 (23)
ADPS-05-2-N	0.80 to 4.00 (200-1000)	0.4 (100)	0.5 (130)
ADPS-06-2-N	2.00 to 10.00 (500-2500)	0.6 (150)	0.8 (200)
ADPS-07-2-N	4.00 to 20.00 (1000-5000)	1.0 (250)	1.4 (350)

**Note:** For optional 1/2" NPT conduit connection, change -2-N to -1-N. Models that include installer kit add -C to the end of the model number (-2-N cable gland models only). Installer kit includes two static tips and 7 ft of PVC tubing. Order installer kit separately with 1/2" NPT conduit connection models. See A-481 in the accessories list.

MODEL CHART - EDPS			
Model	Set Point Range in w.c. (Pa)	Approx. Dead Band @ Min Set Point in w.c. (Pa)	Approx. Dead Band @ Max Set Point in w.c. (Pa)
EDPS-08-1-N	0.08 to 1.20 (20-300)	0.04 (10)	0.05 (12)
EDPS-04-1-N	0.12 to 1.60 (30-400)	0.06 (15)	0.09 (23)
EDPS-03-1-N	0.20 to 2.00 (50-500)	0.08 (20)	0.09 (23)
EDPS-05-1-N	0.80 to 4.00 (200-1000)	0.4 (100)	0.5 (130)
EDPS-06-1-N	2.00 to 10.00 (500-2500)	0.6 (150)	0.8 (200)
EDPS-07-1-N	4.00 to 20.00 (1000-5000)	1.0 (250)	1.4 (350)

**Note:** For optional M20 cable gland connection, change -1-N to -2-N.

MODEL CHART - BDPA			
Model	Set Point Range in w.c. (Pa)	Approx. Dead Band @ Min Set Point in w.c. (Pa)	Approx. Dead Band @ Max Set Point in w.c. (Pa)
BDPA-08-2-N	0.08 to 1.20 (20 to 300)	0.04 (10)	0.05 (12)
BDPA-04-2-N	0.12 to 1.60 (30 to 400)	0.06 (15)	0.09 (23)
BDPA-03-2-N	0.20 to 2.00 (50 to 500)	0.08 (20)	0.09 (23)
BDPA-05-2-N	0.80 to 4.00 (200 to 1000)	0.4 (100)	0.5 (130)
BDPA-06-2-N	2.00 to 10.00 (500 to 2500)	0.6 (150)	0.8 (200)
BDPA-07-2-N	4.00 to 20.00 (1000 to 5000)	1.0 (250)	1.4 (350)

MODEL CHART - BYDS	
Model	Description
BYDS	Bypass damper version
<b>Note:</b> All models available online.	



ACCESSORIES	
Model	Description
A-288	"L" type metal mounting bracket with screws
A-289	"S" type metal mounting bracket with screws
A-480	Plastic static pressure tip
A-481	Installer kit, includes 2 plastic static pressure tips & 7' (2.1 m) of PVC tubing
A-489	4" straight static pressure tip with flange



A-480

Process Tubing Options: See page 489 (Gage Tubing Accessories)

